

10 Gbps SFP Transceiver (UBSFPP-40)

1270/1330nm Single mode 40km Single fiber LC

Features

- Up to 11.3Gb/s bit rates
- 1270nm/1330nm wavelength laser
- Hot-Pluggable
- Single fiber LC receptacle
- Up to 40km on 9/125µm SMF
- Monitoring Interface Compliant with SFF-8472
- Compliant to IEEE 802.3Z & SFP MSA
- Manufactured in an ISO 9001 compliant facility
- Operating temperature range: -40°C to 85°C
- Power dissipation <1.5W
- ROHS-6 Compliant

Applications

- 10G Ethernet Switch and Enterprise Router
- 10G SONET OC-192 / SDH and Fibre Channel
- Other Optical Links

Part numbers

<i>P/N</i>	<i>Data Rate</i>	<i>Wavelength</i>	<i>Connector</i>	<i>Distance</i>
UBSFPP-40-UI	10Gbps	1270nm	LC	40km
UBSFPP-40-DI	10Gbps	1330nm	LC	40km

Absolute Maximum Ratings

Parameter	Symbol	Min.	Typical	Max.	Unit
Storage Temperature	T _s	-40		+85	°C
Supply Voltage	V _{CC} T, R	-0.5		4	V
Relative Humidity	RH	5		95	%

Recommended Operating Environment:

Parameter	Symbol	Min.	Typical	Max.	Unit
Case operating Temperature	T_C	-40		+85	°C
Supply Voltage	$V_{CC,T,R}$	+3.15		+3.45	V
Power Dissipation	P_D			1.5	W

Electrical Characteristics

Parameter	Symbol	Min	Typ	Max	Unit	Note
Transmitter:						
Differential input voltage swing		180		700	mVpp	
Tx Disable	Disable	2.0		Vcc	V	
	Enable	-0.3		0.8	V	
Tx Fault	Assert	2.4		Vcc	V	
	De-assert	-0.3		0.8	V	
Input Differential Impedance	Z_{in}	90	100	110	Ω	
Receiver						
Differential output voltage swing		300		850	mVpp	
LOS Output	Assert	V_{OH}	2.0	Vcc	V	
	De-assert	V_{OL}	-0.3	0.4	V	
Output Differential Impedance	Z_{on}	80	100	120	Ω	

Optical Parameters

Parameter	Symbol	Min	Typ	Max	Unit	Ref.
Transmitter						
Bit Rate	BR	9.9		11.3	Gb/s	
Optical Wavelength	UBSFPP-40-UI	λ	1260	1270	1280	nm
	UBSFPP-40-DI		1320	1330	1340	
Average output power	P_o	0		+5	dBm	
Optical Extinction Ratio	ER	3.5			dB	
Spectral width	$\Delta\lambda$			1	nm	
Side Mode Suppression Ratio	SMSR	35			dB	
Receiver						
Bit Rate	BR	9.9		11.3	Gb/s	
Optical Wavelength	UBSFPP-40-UI	λ	1320	1330	1340	nm
	UBSFPP-40-DI		1260	1270	1280	
Receiver Sensitivity	Sen			-15	dBm	1

10 Gbps SFP Transceiver (UBSFPP-40)

1270/1330nm Single mode 40km Single fiber LC

Maximum Input Power	P _{MAX}	-3			dBm	
LOS De-Assert	LOS _D			-16	dBm	
LOS Assert	LOS _A	-25			dBm	
LOS Hysteresis	LOS _H	0.5		4	dB	

Notes:

Note 1) Measured with a PRBS of 2³¹-1 at 1 x 10⁻¹² BER and 3.5 dB extinction ratio.

Pin Assignment

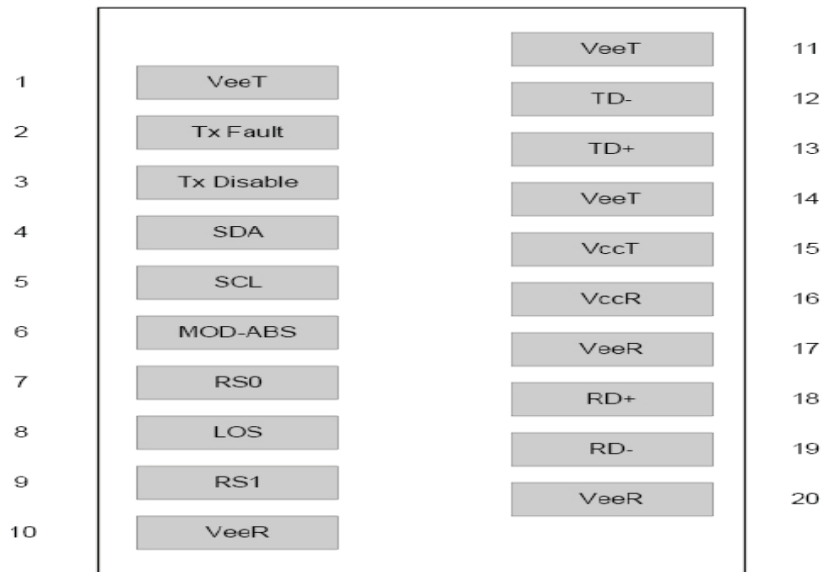

Pin Function Definitions

PIN #	Name	Function	Notes
1	VeeT	Module transmitter ground	1
2	Tx Fault	Module transmitter fault	2
3	Tx Disable	Transmitter Disable; Turns off transmitter laser output	3
4	SDL	2 wire serial interface data input/output (SDA)	
5	SCL	2 wire serial interface clock input (SCL)	
6	MOD-ABS	Module Absent, connect to VeeR or VeeT in the module	2
7	RS0	Rate select0, optionally control SFP+ receiver. When high, input data rate >4.5Gb/s; when low, input data rate <=4.5Gb/s	
8	LOS	Receiver Loss of Signal Indication	4
9	RS1	Rate select0, optionally control SFP+ transmitter. When high, input data rate >4.5Gb/s; when low, input data rate <=4.5Gb/s	
10	VeeR	Module receiver ground	1
11	VeeR	Module receiver ground	1

12	RD-	Receiver inverted data out put	
13	RD+	Receiver non-inverted data out put	
14	VeeR	Module receiver ground	1
15	VccR	Module receiver 3.3V supply	
16	VccT	Module transmitter 3.3V supply	
17	VeeT	Module transmitter ground	1
18	TD+	Transmitter inverted data out put	
19	TD-	Transmitter non-inverted data out put	
20	VeeT	Module transmitter ground	1

Note 1) The module ground pins shall be isolated from the module case.

Note 2) This pin is an open collector/drain output pin and shall be pulled up with 4.7K-10Kohms to Host_Vcc on the host board.

Note 3) This pin shall be pulled up with 4.7K-10Kohms to VccT in the module.

Note 4) This pin is an open collector/drain output pin and shall be pulled up with 4.7K-10Kohms to Host_Vcc on the host board.

SFP Module EEPROM Information and Management

The SFP modules implement the 2-wire serial communication protocol as defined in the SFP -8472. The serial ID information of the SFP modules and Digital Diagnostic Monitor parameters can be accessed through the I²C interface at address A0h and A2h. The memory is mapped in Table 1. Detailed ID information (A0h) is listed in Table 2. And the DDM specification at address A2h. For more details of the memory map and byte definitions, please refer to the SFF-8472, “Digital Diagnostic Monitoring Interface for Optical Transceivers”. The DDM parameters have been internally calibrated.

Table 1. Digital Diagnostic Memory Map (Specific Data Field Descriptions)

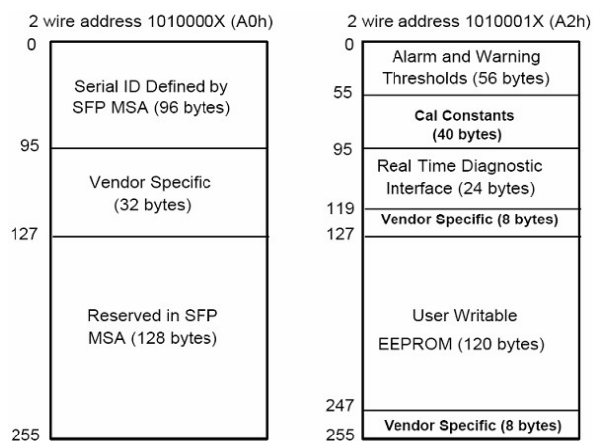

Table 2 - EEPROM Serial ID Memory Contents (A0h)

Data Address	Length (Byte)	Name of Length	Description and Contents
Base ID Fields			
0	1	Identifier	Type of Serial transceiver (03h=SFP)
1	1	Reserved	Extended identifier of type serial transceiver (04h)

10 Gbps SFP Transceiver (UBSFPP-40)
 1270/1330nm Single mode 40km Single fiber LC



2	1	Connector	Code of optical connector type (07=LC)
3-10	8	Transceiver	10G Base-LR
11	1	Encoding	64B/66B
12	1	BR, Nominal	Nominal baud rate, unit of 100Mbps
13-14	2	Reserved	(0000h)
15	1	Length(9um)	Link length supported for 9/125um fiber, units of 100m
16	1	Length(50um)	Link length supported for 50/125um fiber, units of 10m
17	1	Length(62.5um)	Link length supported for 62.5/125um fiber, units of 10m
18	1	Length(Copper)	Link length supported for copper, units of meters
19	1	Reserved	
20-35	16	Vendor Name	SFP vendor name
36	1	Reserved	
37-39	3	Vendor OUI	SFP transceiver vendor OUI ID
40-55	16	Vendor PN	Part Number (ASCII)
56-59	4	Vendor rev	Revision level for part number
60-62	3	Reserved	
63	1	CCID	Least significant byte of sum of data in address 0-62
Extended ID Fields			
64-65	2	Option	Indicates which optical SFP signals are implemented (001Ah = LOS, TX_FAULT, TX_DISABLE all supported)
66	1	BR, max	Upper bit rate margin, units of %
67	1	BR, min	Lower bit rate margin, units of %
68-83	16	Vendor SN	Serial number (ASCII)
84-91	8	Date code	Manufacturing date code
92-94	3	Reserved	
95	1	CCEX	Check code for the extended ID Fields (addresses 64 to 94)
Vendor Specific ID Fields			
96-127	32	Readable	Specific date, read only
128-255	128	Reserved	Reserved for SFF-8079

Digital Diagnostic Monitor Characteristics

Data Address	Parameter	Accuracy	Unit
96-97	Transceiver Internal Temperature	±3.0	°C
98-99	VCC3 Internal Supply Voltage	±3.0	%
100-101	Laser Bias Current	±10	%
102-103	Tx Output Power	±3.0	dBm
104-105	Rx Input Power	±3.0	dBm

Regulatory Compliance

Electrostatic Discharge (ESD) to the Electrical Pins	MIL-STD-883E Method 3015.7	Class 1(>1000 V)
Electrostatic Discharge (ESD) to the Single LC Receptacle	IEC 61000-4-2 GR-1089-CORE	Compatible with standards
Electromagnetic Interference (EMI)	FCC Part 15 Class B EN55022 Class B (CISPR 22B) VCCI Class B	Compatible with standards
Laser Eye Safety	FDA 21CFR 1040.10 and 1040.11 EN60950, EN (IEC) 60825-1,2	Compatible with Class 1 laser

Recommended Circuit

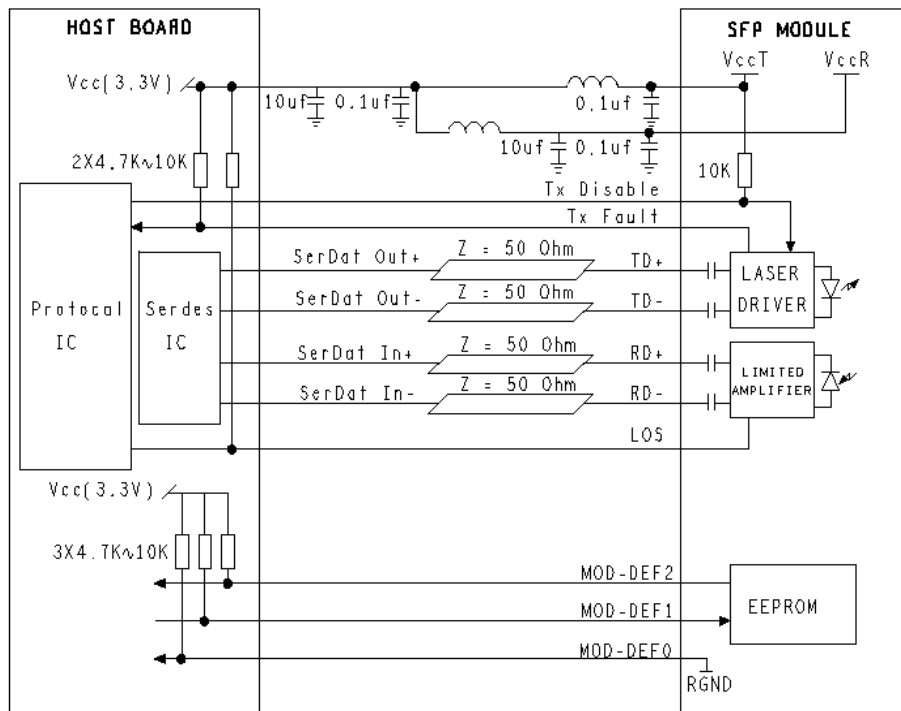

10 Gbps SFP Transceiver (UBSFPP-40)
1270/1330nm Single mode 40km Single fiber LC

Mechanical Dimensions

